

Big Bang, Small Bucks; Effective Use of Low-Cost CAD Packages

Ravi Pendse and Everett L. Johnson
Wichita State University

Abstract

At Wichita State University we have implemented an undergraduate three-course sequence in digital system design and computer architecture. Key to the success of these courses are two inexpensive yet very effective software packages called B2Logic [1] and Logic-Aid[2]. Both packages are very user friendly, requiring little practice to become proficient in their use. After the first two courses the students are familiar with both packages. By the end of the third course, Introduction to Computer Design, they will have developed a complete 4-bit processor using the B2Logic package. Using the simulation feature of the package they can load and run actual programs. As semester projects the students are required to add various features to the processor they have designed such as push-down stacks, branching instructions, etc.

Introduction

At Wichita State University we have View Logic's Work View Plus CAD package. This package is very powerful but requires more instruction than can be given in a semester course. The B2Logic and Logic Aid packages require a much shorter learning time and provide a natural introduction to the more powerful but more difficult to use Work View Plus. The availability of PCs and brilliant low cost packages provides even small schools the opportunity of introducing students to techniques formerly available only to departments with larger budgets.

At Wichita State University we have a three course sequence in digital system design.

- EE194 Introduction to Digital Design. 4 Semester credit hours, 3 hours lecture, 3 hours of lab.
- EE294 Digital Design Techniques 3 Semester hours.
- EE394 Introduction to Computer Architecture 3 Semester hours.

EE 194 is offered to first semester students as part of our Early Entry Program. The only prerequisite is college algebra. The first year students have been very successful in this course. Enrollment in the course allows them to have access to the department LAN. Assignments and results are submitted via the LAN. The first year students not only have a design experience but become a part of the department early in their college experience. The result has been improved retention and better design skills. Having their first laboratory experience in the department under a very capable instructor has improved the students performance in out-of-the-department laboratory classes. The three course sequence allows a continuing design experience while taking introductory courses in circuits and electronics.

After EE194 and EE294, the students are proficient in the use of B2Logic and Logic Aid. Throughout the semester, in EE394, the students design various portions of a 4-bit limited-instruction-set processor, LIS-4. The LIS-4 architecture and design are taken from a text that is no longer in print [1]. Figure 1 shows the basic architecture.

Semester Design Activity

The design progression is as follows:

- Design a 4-bit register with inputs; clock, enable input (EI), enable output (EO), a tri-stated output controlled by EO and a direct output. This circuit is designed and designated as a user-defined circuit for use as each register in the LIS4.
- Design the Arithmetic Logic Unit (ALU) using the Logic Aid package and design it as a user defined circuit. The ALU has only 4 functions - ADD, AND, INCREMENT and FAST TRANSFER.
- Combine the registers and ALU together and designate the resultant circuit as a user defined circuit. The students are encouraged to bring out as pins the direct connection to each register so they can follow the progress of an instruction execution. All the control signals, BO, and BI must be defined as pins also. The students are instructed to design

the register and ALU circuit so that the stack register and memory circuits can be attached externally.

- Design the control section. The Execute Address look-up ROM which uses the opcode to determine the address of the microsteps controlling the execute portion of the instruction is programmed and connected to the counters used as the address register for the control ROM. The control ROM is then programmed with the micro-code necessary to perform fetch and execute for each of the 16 instructions.

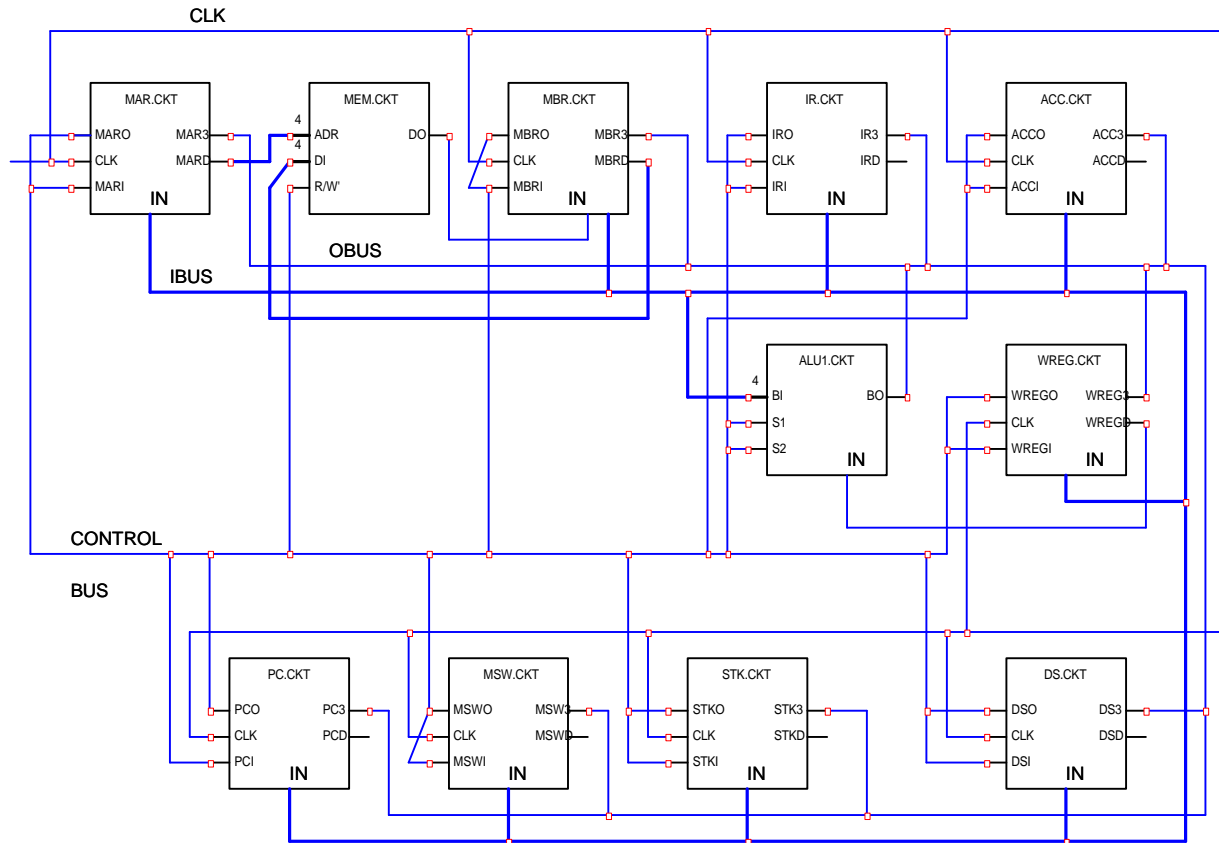

Figure 1. LIS-4 Block Diagram

MAR - Memory Address Register
 MBR - Memory Buffer Register
 IR - Instruction Register
 PC - Program Counter
 ACC - Accumulator
 ALU - Arithmetic Logic Unit
 WREG - Working Register
 MSW - Memory Switch Register (Page)

STK - Stack Register
 DS - Device Select Register
 Control Lines - Come from the Control ROM
 XXXO - Connects the XXX Register to the bus
 XXXI - Enables the Input Bus to the Register XXX

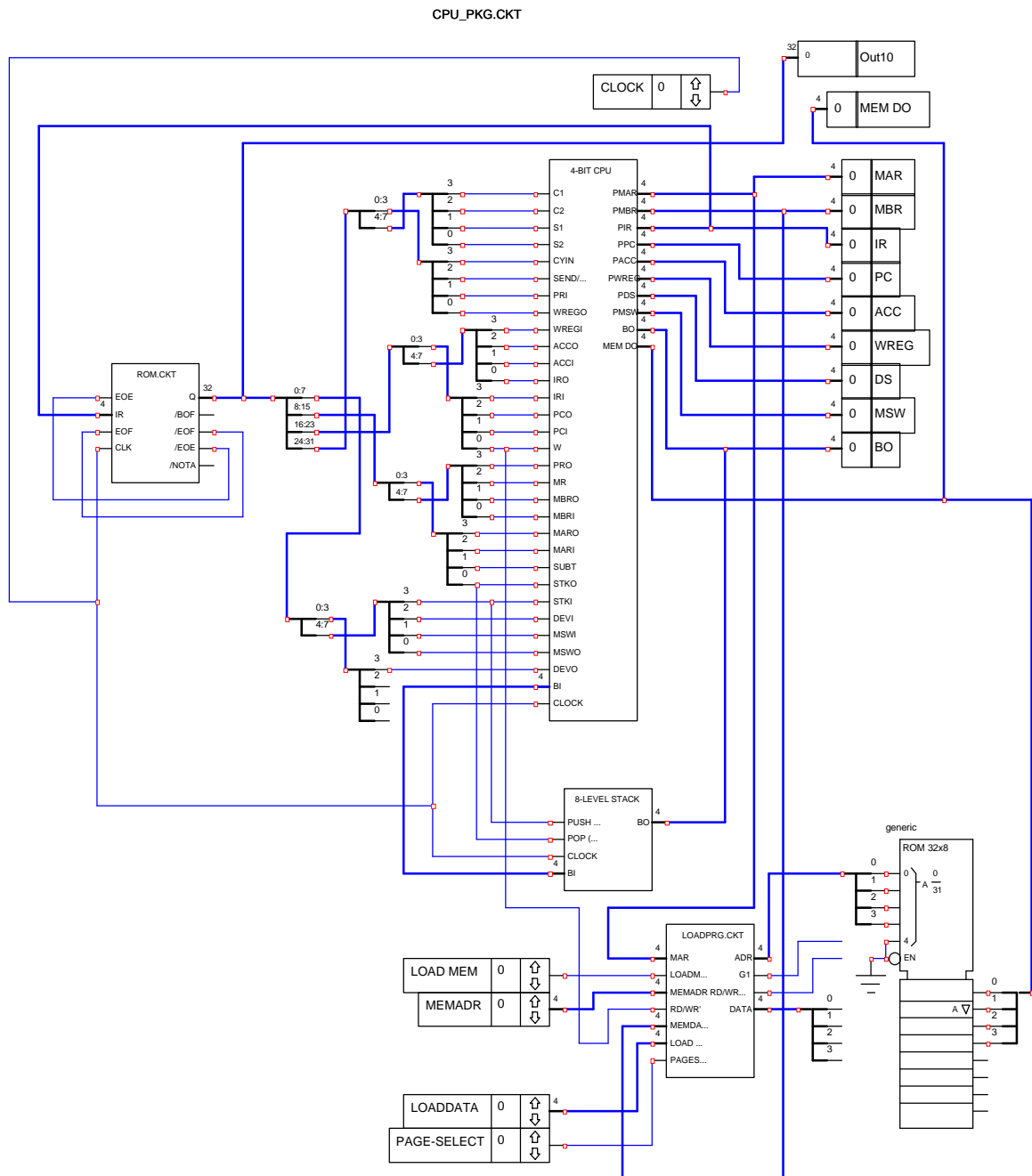

Figure 2. Student's Working LIS-4 Design

With the addition of RAM (or ROM) for storing a program, the system is ready to operate. Figure 2 shows one student's final working circuit. After a working model is completed, the students are then assigned modifications in or additions to the architecture. Typical problems assigned have been:

- Add an eight level push-down stack.
- Convert to a single bus system
- Add instructions of various types

Conclusion

B2Logic allows the student to design a processor, run programs and follow the data through the architecture, add or modify instructions using micro-code, and view the timing diagrams of selected signals in the system. The student has the opportunity to design and correct errors in a working processor without having to build the circuit. B2Logic and Logic Aid are not the only inexpensive packages available but at Wichita State University, we have found them to be effective in teaching logic design.

References

1. B2logic - B2logic is a Computer Aided Design package developed and marketed by Beige Bag Software. The package provides libraries of components of 74xxx, 74LSxxx, and generic devices. After circuits are designed they can be declared as user defined components and used as components in future designs. All device characteristics can be modified by the user.

The simulation capabilities allow either timing diagram or tabular presentation of time dependent data. Tools for use during development are zoom, logic probe, single time increment advance (adjustable), and clock controlled (frequency and duty cycle are selectable).

The Company can be contacted at:

Beige Bag Software
715 Barclay Ct.
Ann Arbor, MI 48105
(313) 663-4309
E-mail 7162.3474@compuserve.com

2. Logic Aid - Logic Aid is a software package which allows reduction of logic equations entered as truth tables, Karnaugh maps, or equations. Reduced equation form, sum-of-product or product-of-sum, is selectable.

Sequential design problems may be entered as state diagrams or state tables. The resultant flip-flop excitation equations are available for JK, T, or D flip-flops. The program is very user friendly. Information about obtaining copies of this software should be made to:

West Services, Inc.
620 Operman Drive
P.O. Box 64779
St. Paul, Minnesota 55164-0779

3. E. L. Johnson and M. Karim, Digital Design: A Pragmatic Approach, 1987, PWS